

ASSEMBLY INSTRUCTION

MODEL : 7050 / SHOE RACK

STEP 1

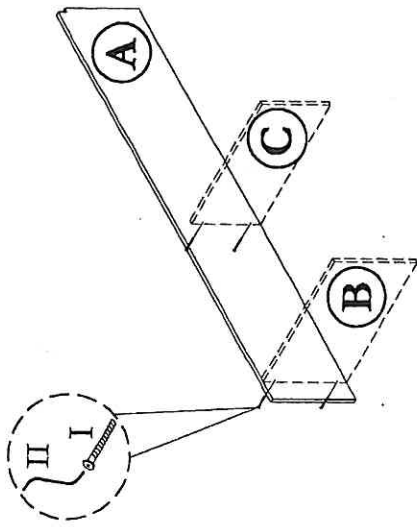

STEP 2

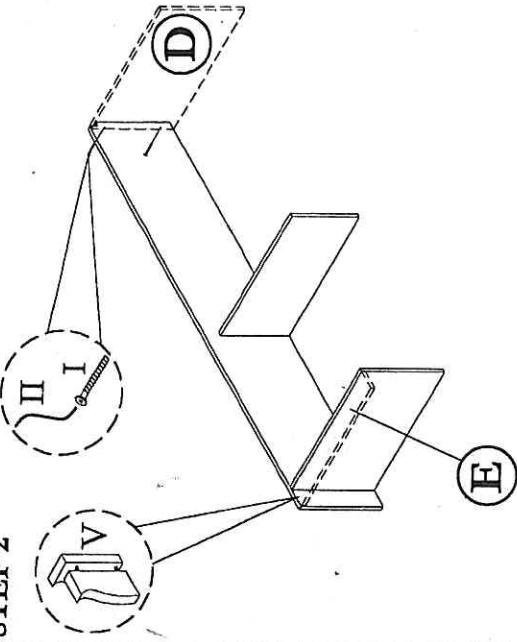

STEP 3

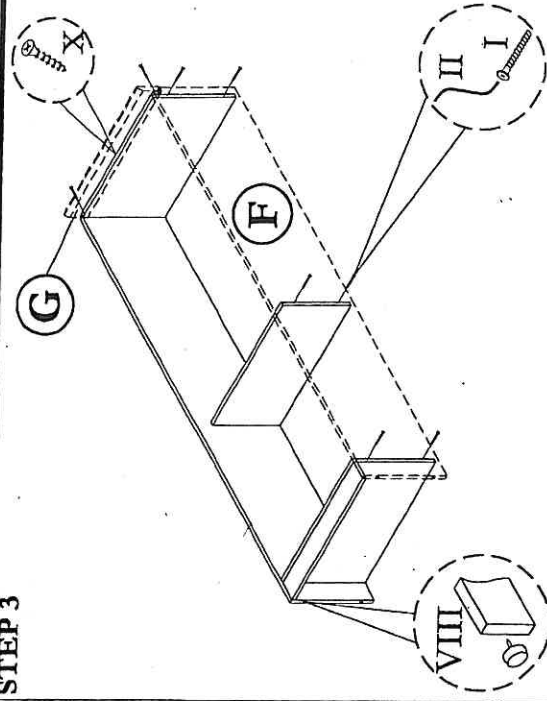

STEP 4

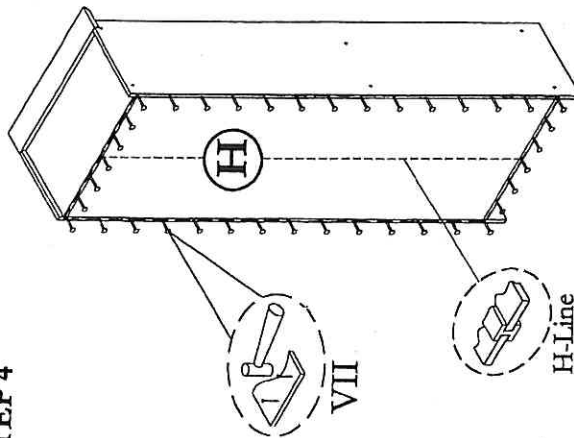

STEP 5

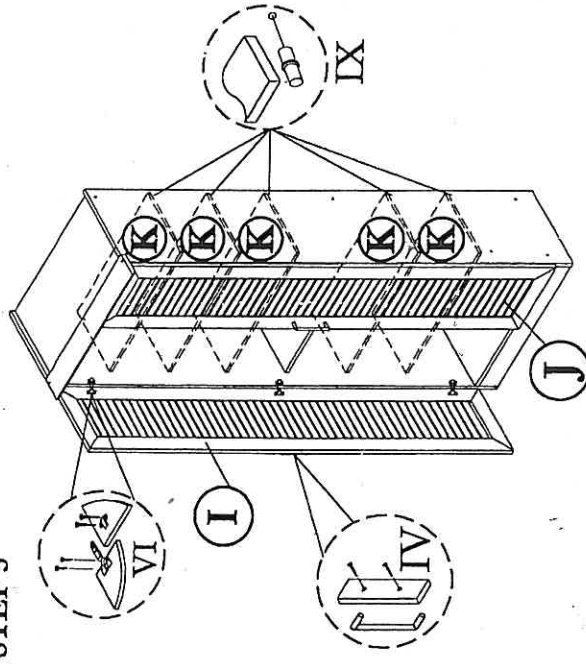

STEP 6

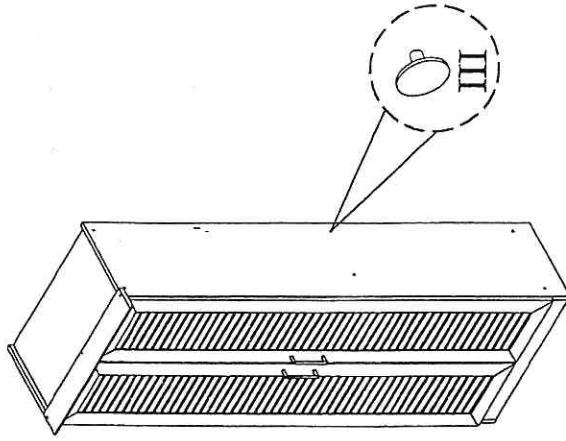

Before you begin, please follow assembly instruction carefully.
Then follow them step by step.

HARDWARE LIST	
NO	DESCRIPTION
I	JCBCW SCREW M6 x 45
II	M4 ALLEN KEY
III	CAP SMALL

IV	HANDLE & SCREW M3.5 x 30	2sets
V	M8 x 30 PLASTIC DOWEL	4pcs
VI	HINGES & SCREW M3.5 x 16	6sets
VII	NAIL	50pcs
VIII	PVC NAIL WITH PIN	4pcs

IX	PVC SHELF SUPPORT	20pcs
X	M3.5 x 30 CHIPBOARD SCREW	1pc

CAUTION:

To clean use soft, dry cloth. Do not use detergent or chemicals
Avoid contact with water and direct sunlight.
To be assembled on a soft, dry, clean and smooth surface.

ORDERING REPAIR PARTS

In order to obtain smooth and rapid service when ordering repair parts,
please give full attention to the following of PART NUMBER.

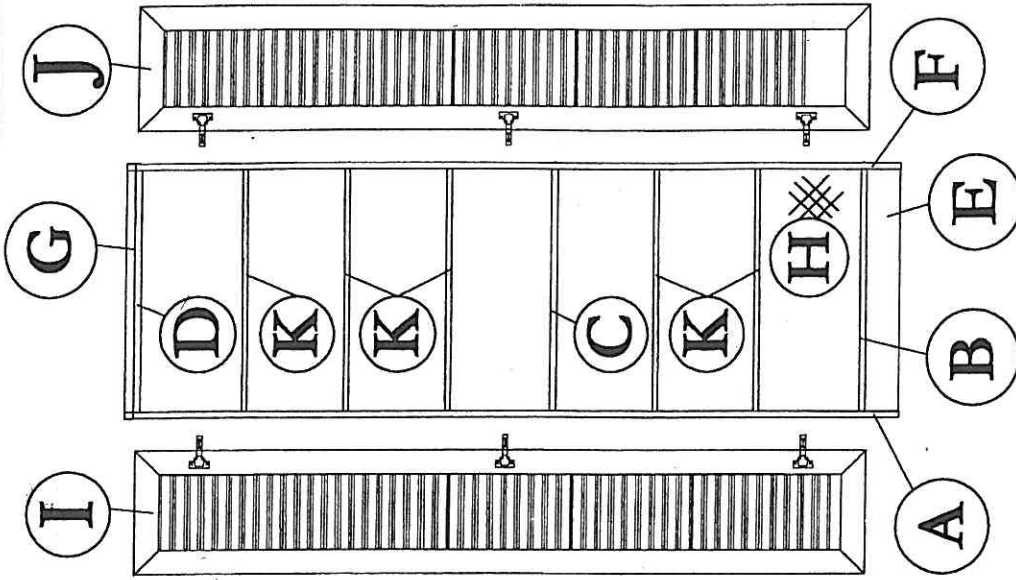
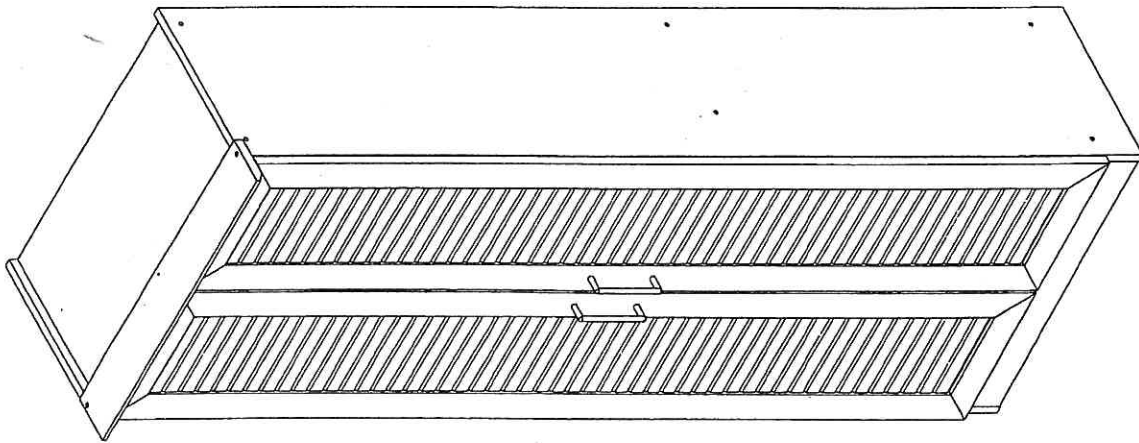

NO	DESCRIPTION	QTY
A	LEFT SIDE	01
B	LOWER SHELF	01
C	CENTRE SHELF	01
D	UPPER SHELF	01
E	LEG	01
F	RIGHT SIDE	01

NO	DESCRIPTION	QTY
G	TOP	01
H	BACK	02
I	LEFT SIDE DOOR	01
J	RIGHT SIDE DOOR	01
K	MOVABLE SHELF	05

COMPLETE SET